

# VOLKSWAGEN

Group Motorsport



Volkswagen Motorsport  
Customer Racing



---

## DSG Gearbox revision service

Application to:

- VAG cars with DSG gear box
- ~~VAG cars with Sequential gear box~~

# DSG GEARBOX REVISION

## Service & Gearbox exchange information

Dear Customer:

-Volkswagen Group Motorsport advise about rebuilding the DSG gearbox and the electronic slip differential service.

**Maintenance Revision at 4.000 km → Price 4.000€**

Information about revisions will only apply to European customers.

For NO European customers, please contact your partner.

-Gear Box revision /Terms and conditions:

The accumulated mileage recommended for a maintenance revision is around 4000km.

Gearboxes up to 8000 km will not be accepted for service

Pre-evaluation bench test before disassembling

Removing, cleaning and reassembling all internal components

Replacement of ratios 3<sup>rd</sup>, 4<sup>th</sup>, 5<sup>th</sup>, syncros, bearings, Diff pump and oils

Specific clutch control check

Mechatronic transmission electronic adjustments after rebuilding

Performance control on dyno test

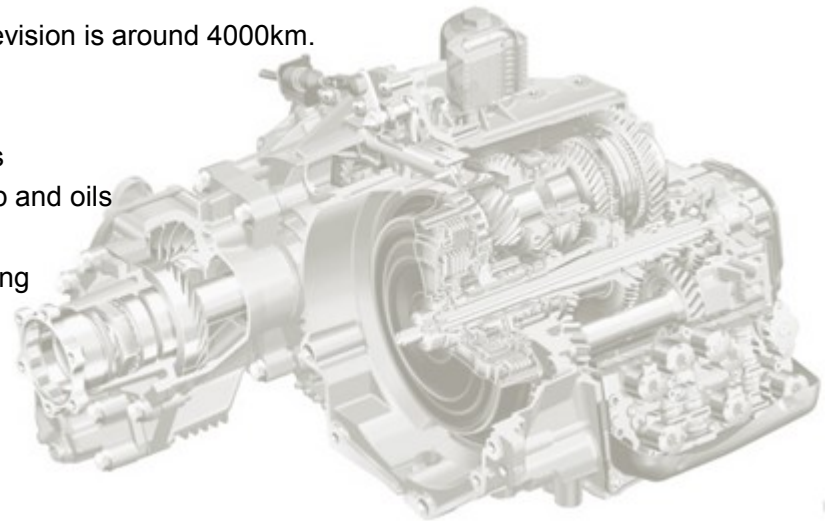

# DSG GEARBOX REVISION

## Delivery Information

ONLY FOR EU CUSTOMERS

Before sending parts contact us by e-mail [technical@cupraofficial.com](mailto:technical@cupraofficial.com) and [customers@cupraofficial.com](mailto:customers@cupraofficial.com)

Parts to be revised must be delivered by the customer at shipping address:

**SEAT CUPRA S.A.**  
**Avda. Can Amat, 7**  
**08630 Abrera, Spain**

Parts to be revised must be packed in a proper box and in a EUR pallet

Parts to be revised must present attached the “Revision & Gearbox exchange request document”, (also available on the web download area)

After revision CUPRA will send the quotation and payment copy.

Parts will be send returned to customers by TNT economy service (European destination: DDP incoterms, NO EU countries: FCA incoterms).

CUPRA will not handle any warranties regarding the gearbox revisions.

Box must include:

Gearbox and VAQ assembled.

Breather pipe closed.

Oil intercooler pipes closed.

Protect the VAQ differential electronic unit, placed under the differential

In case of technical doubt, please contact by e-mail [technical@cupraofficial.com](mailto:technical@cupraofficial.com)

