

VOLKSWAGEN

Group Motorsport



TCR Technical Bulletin; 2nd Inlet Air Temperature Sensor for Scrutineering

Application to:

- VAG cars with Sequential gear box
- VAG cars with DSG gear box

TN_VAG_02/ 2021

2nd Inlet Air Temperature Sensor for scrutineering

2021 TCR TECHNICAL BULLETIN n1. 02/2021-02-24

The decision is with immediate application and valid until further notice.

2021 TCR Technical Regulations Art. 3,6; Data Logging

The 2nd Inlet Air Temperatures Sensor will be mandatorily use only on request of each TCR Series promoter-

Applicable to the following VAG models: *(use only on request of each TCR Series promoter)*

- CUPRA LEON CUP RACER (MK3)
- VW Golf GTI TCR
- Audi RS 3 LMS (MY prior to 2021)

2nd Inlet Air Temperature Sensor for scrutineering

Mounting:

Replace the inlet hose (11) for the new inlet hose, part no; 5F6145838

Install the inlet temperature sensor into the engine inlet hose, par no; 5FR91937

Cabling is required between the air inlet temperature sensor and the scrutineering data logging system AIM EVO4/5.

Suppliers:

[Volkswagen Group Motorsport – Online Platform \(vwgroupmotorsport-onlineplatform.com\)](http://vwgroupmotorsport-onlineplatform.com)

INLET HOSE ref: **5F6145838**

T-INT SENSOR ref: **5FR919379**

FRW SRL:

Connection wire available at the following address only;

CONNECTION WIRE ref: **TCR-AITSC-v20.1.0**

FRW SRL

Via della Tecnica 26

36100, Vicenza, Italia

Desirèe Falcomer - commercial@frw-wires.com

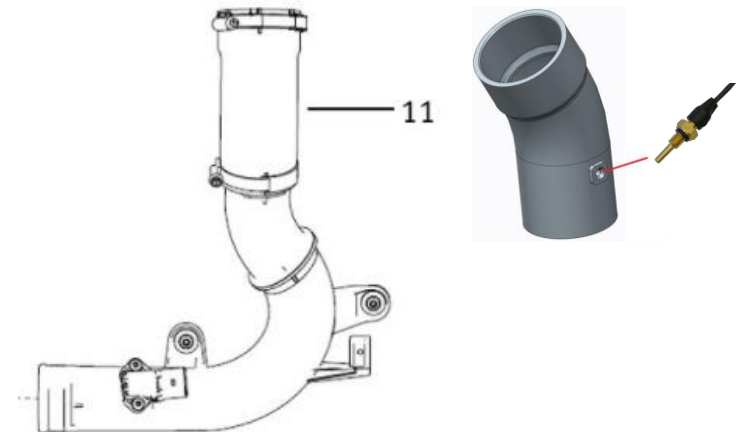

*TCR mounting instructions document “TCR-Air-TempSend-Manual” available in the VA Group download area into the corresponding car models.